

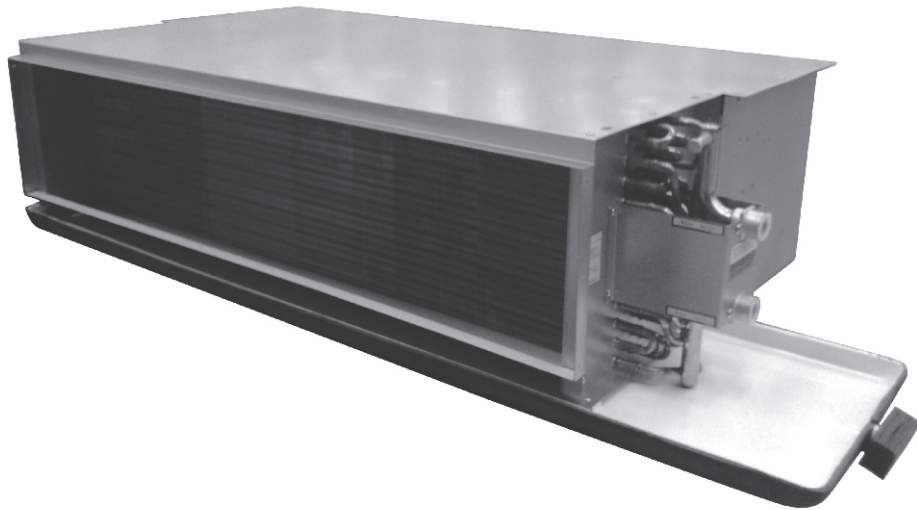

YDFC-MDE Fan Coil Unit

INSTALLATION, OPERATION & MAINTENANCE

Form No.: YDFC MDE-03IOM(YGF)(1118)



Ceiling Concealed with Back Return Plenum Model

WARNING TO INSTALLER, SERVICE PERSONNEL AND OWNER

Altering the product or replacing parts with non authorized factory parts voids all warranty or implied warranty and may result in adverse operational performance and/or a possible hazardous safety condition to service personnel and occupants. Company employees and/or contractors are not authorized to waive this warning.



Note the CE certification is only applicable to 50Hz unit

Table of Content

Table of Content	2
Overview	3
Determination of Right-Handed / Left-Handed References	3
Receiving	3
Storage	3
Prepare Ceiling for Mounting	3
Wiring	4
Installation	5
Piping	5
Pipe Sizes	5
Valve Cluster	6
2-Way Motorized Valve Assemblies	6
3-Way Motorized Valve Assembly	6
Drain Piping	7
YDFC-MDE – Nomenclature	8
Outlines, Dimensions and Weight	9
Ceiling Concealed Model with Back Return Air Plenum	9
Weight	11
Fan Coil Start-Up Checklist	12
Install Checklist	12
Cleaning Checklist	12
Controls Checklist	12
Fan Inspection	12
Maintenance and Service of Product	13
Motor	13
Coil	13
Filters	13
Clean Unit Interior	13
Troubleshooting	14

Overview

Johnson Controls Fan Coil Unit is designed for many exposed and concealed applications. The fan-coil market of today demands the high-performance, flexibility and quality available in this completely redesigned product that sets it apart from the competition.

The YDFC Fan Coil Unit is designed for long, safe and efficient product life. With today's focus on Indoor Air Quality, the Johnson Controls Fan Coil Unit gives you the flexibility to incorporate one or more IAQ features into your building's design.

YDFC-MDE fan coil unit are constructed of precisely formed, heavy gauge galvanized steel. Individual fan and coil modules are securely fastened together to create a solid, high-performance unit. Cabinet models are painted with the latest in electrostatic painting techniques. It's the same process used to paint our rugged, outdoor chillers, and provide a durable attractive finish.

Determination of Right-Handed / Left-Handed References

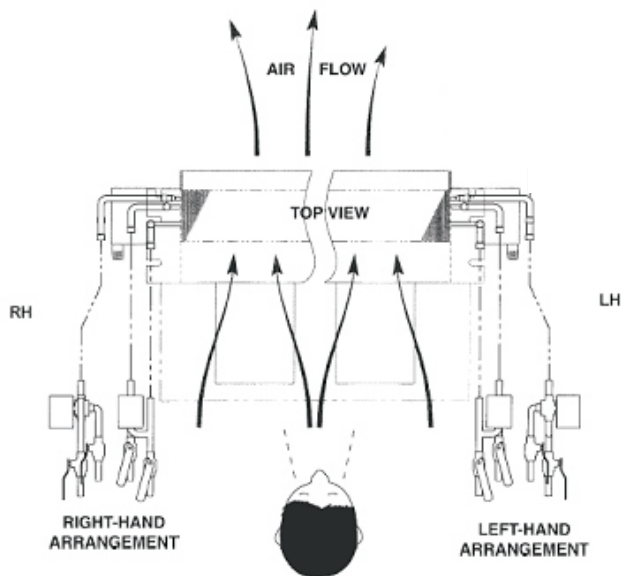

Receiving

Material in this shipment has been inspected at the factory and released to the transportation agency in good condition. When received, a visual inspection of all cartons should be made immediately. Any evidence of rough handling or apparent damage should be noted on the delivery receipt and the material inspected in the presence of the carrier's representative.

Storage

If the equipment is not to be immediately installed, store it in a dry location with the motor protected against moisture, dust, corrosion and physical damage.

Prepare Ceiling for Mounting

Depending upon building construction, provisions for mounting the unit must be made by the contractor according to architects' drawings.

It is important to ensure that the fan coils are securely mounted and the structure is sufficient to support the weight of the equipment. All anchors for mounting the equipment must be placed and sized to ensure a safe and durable installation.



If damage is found, a claim should be filed against the carrier immediately.

The YDFC-MDE CB models are designed for installation in a horizontal position above a dropped ceiling.

In free (non-ducted return air) return installations of YDFC-MDE product; the furred down area must be completely sealed (except return air grille) to ensure that all return air is pulled from the conditioned space and not from other areas of the building structure.

Access must be provided for servicing the unit. If this access is provided by a removable ceiling panel, ample space must be allowed for removal of the blower panel and to provide access to electrical and plumbing controls.



Unit must not be operated during building construction due to excessive airborne dust and debris. The units must not be operated under any circumstances without an air filter in place.



The dimensions of the space necessary for correct installation of the appliance including the minimum permissible distances to adjacent structures.

Prepare Wall for Mounting

Depending upon building construction, provisions for mounting the unit must be made by the contractor according to architects; drawings.



It is recommended that appliance is installed beyond the height of 2.3 meter.



The appliance is only for indoor use and shall not be installed in the laundry



It is recommended that all mounting holes be used for proper installation.



Unit must not be operated during building construction due to excessive airborne dust and debris. The units must not be operated under any circumstances without an air filter in place.

Wiring

All wiring must comply with the local and national code requirements. Units are provided with wiring diagrams and nameplate data to provide information required for necessary field wiring.



Any devices such as fan switches or thermostats that have been furnished by the factory for field installation must be wired in strict accordance with the wiring diagram that is supplied with the unit. Failure to do so could result in damage or injury.



If the supply cord is damaged, it must be replaced by the manufacturer or its service agent or a similarly qualified person in order to avoid a hazard.



It is recommended that appliance is installed beyond the height of 2.3 meter.



The appliance shall be installed in accordance with national wiring regulations



An all-pole disconnection device which has at least 3mm separation distance in all pole and a residual current device(RCD) with the rating of above 10mA shall not be incorporated in the fixed wiring according to the national rule.

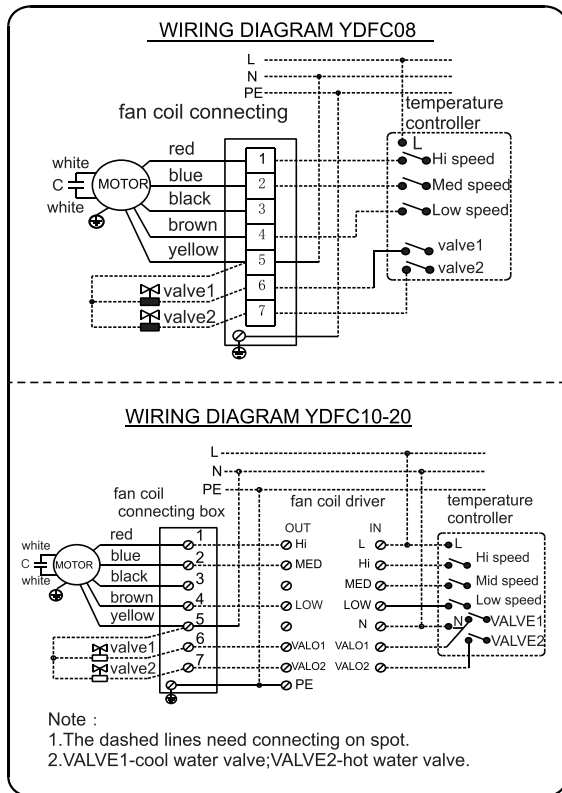

Typical Wiring Diagram

Installation

The installation mounting holes are provided for the unit. Metal washers and nuts of the proper size are to be provided by the installer. When necessary, use shims to obtain the proper level. This will ensure that the condensate will drain from the unit.

Piping

These units employ a hydraulic coil designed for use with either hot or chilled water. All piping must be adequately sized to meet the design water flow requirements as specified for the specific installation. Piping must be installed in accordance with all applicable codes.

Pipe Sizes

All models:

- Size 08~14 Standard CW coils are 1" OD tubing.
- Size 16~20 Standard CW coils are 1 1/2" OD tubing.
- Size 08~20 District CW coils are 3/4" ID tubing
- Size 08~20 HW coils are 3/4" ID tubing

Manual air vents are provided standard on all coils. All chilled water piping must be insulated to prevent condensation.



Prior to connecting to the fan coil, all external piping must be purged of debris.



When connecting piping or valve kits to fan coil units, do not bend or reposition the coil header tubing for alignment purposes. This could cause a tubing fracture resulting in a water leak when water pressure is applied to the system.



The minimum permissible distance form the adjacent combustible material to the electric heater surface should be 300mm when the unit is equipped with electric heater.

Precautions

1. Flush all fields piping prior to connection to remove all debris.
2. Use wet cotton rags to cool valve bodies when soldering.
3. Open all valves (mid-way for hand valves, manually open on motorized valves) prior to soldering.
4. When soldering to bronze or brass, heat the piping while in the socket/cup and begin introducing the solder when the flux boils rapidly. Avoid direct flame into the solder joint.
5. Heat can only be applied to the cup of the valve body for a minimal time before damage occurs (even with the use of wet rags).
6. Avoid rapid quenching of solder joints, as this will produce joints of inferior quality.
7. The valve package will not support the weight of the connecting pipes. All pipes, which are connected to the units, must be completely supported prior to connection to the unit.
8. Provisions must be made for expansion and contraction of piping systems. All horizontal and vertical risers, including run outs, must be able to withstand significant movement with temperature changes. Failure to do so will result in damage and failure of piping, fittings and valves throughout the building.
9. Never insulate the heads or motorized portion of control valves. Damage can occur in the form of excessive heat build up and interference to the operation and moving parts will result.
10. All piping made in the field should be installed with consideration of additional space for any electrical routing that may be required.

- Hydraulic systems are not designed to hold pressurized air and should only be tested with water.

After the system has been proven leak free, all lines and valve control packages must be insulated as specified on the building plans.

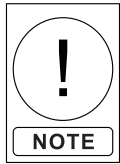

Many valve packages will not physically allow all components to fit over an auxiliary drain pan. It is the installer's responsibility to ensure adequate condensation prevention. The installer must also ensure that there is no condensate drippage onto electrical components beneath insulated components.

installed with the power head above horizontal. The actuator box requires a 3/4" clearance for removal.

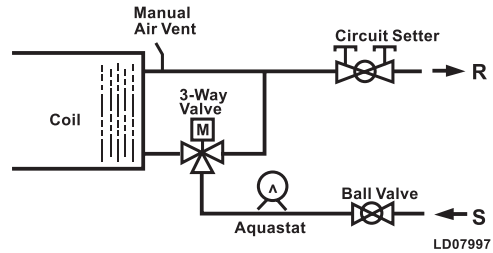

Valve Package

2-Way Motorized Valve Assemblies

- The motorized valve assembly should be attached to the supply header, which is the connection nearest the air outlet flange on the unit.
- Prior to soldering the joints, operate all the hand valves to ensure that the handles will fully open and close without interference to other valves, ceiling, wall, plenum or other accessories.
- All valves will operate at any angle with the exception of the motorized valve, which must be installed with the power head above horizontal. The actuator box requires a 3/4" clearance for removal.

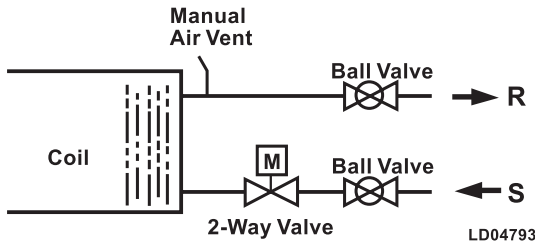

3-Way Motorized Valve Assembly

- The 3-way valve assemblies will mount to the coil in only one position. On four-pipe right hand systems, a "B" valve assembly is required for the chilled water connection and an "A" valve assembly is required for the hot water connection. On left hand systems, an "A" valve assembly is required for the chilled water connection and the hot water connection.
- Prior to soldering the joints, operate all the hand valves to ensure that the handles will fully open and close without interference to other valves, ceiling, wall, plenum or other accessories.
- All valves will operate at any angle with the exception of the motorized valve, which must be

Drain Piping

Condensate drain lines must be installed with adequate slope away from the unit to assure positive drainage. Minimum trap of 1-1/2 inches be provided in the drain line to assure proper drainage. However, a trapped condensate line is recommended to ensure proper drainage of unit in case a negative condition should occur.

The drain should always be connected or piped to an acceptable disposal point sloped away from the unit at least 5° per foot.

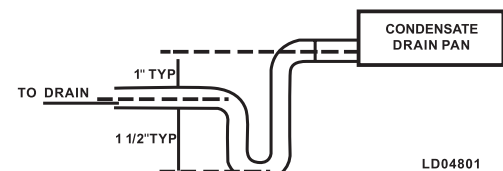

Typical Condensate Piping

Drain line installation must adhere to all code requirements. The plastic auxiliary drain pan is to be located under the coil/valve connections supported by its mounting bracket. Make sure drain pan is level for proper drainage.

The auxiliary drain pan connection is suitable to receive a standard 3/4" PVC coupling or elbow. Route the condensate line such that it will have adequate slope from the pan to the drain. After condensate line has been run, make sure plastic drain line from blower plate nipple is routed to plastic auxiliary drain pan and plastic cap is installed on other nipple on the blower plate.



Remove or cover the secondary drain pan before soldering the supply and return coil connections as hot solder or the torch flame may damage the pan.

TUC03 Controller Package

To improve customer's satisfaction, factory-mounting and commissioning control package is available, the TUC03 controller will provide direct digital control of fan coil unit applications with heating/cooling coils, an electric heater and a three-speed fan.

It is ease of use and low field installation and commissioning cost.

Please see the relative documents for the details



TUC03
Terminal Unit Controller



LP-RSM003-000C



LP-RSM003-001C



LP-RSM003-003C
and LP-RSM003-004C

Communicating Infra-Red (IR) Room



TM Series



RS Series

Non-communicating (Parallel Wired)
Room Sensor Modules

Working Condition

- Circumstance: altitude should not be higher than 1000 meter; air dry bulb temperature is $\leq 40^{\circ}\text{C}$, relative humidity is $\leq 95\%$.
- Water temperature: chilled water is $\geq 5^{\circ}\text{C}$, hot water $\leq 80^{\circ}\text{C}$ (generally 60°C).
- Water pressure: maximum working pressure of coil is 1.6Mpa.
- Power supply: single phase 220~240V,50Hz or 220~240V,60Hz.

Disposal



Do not dispose this product as unsorted municipal waste, collection of such waste separately for special treatment is necessary.

YDFC-MDE – Nomenclature

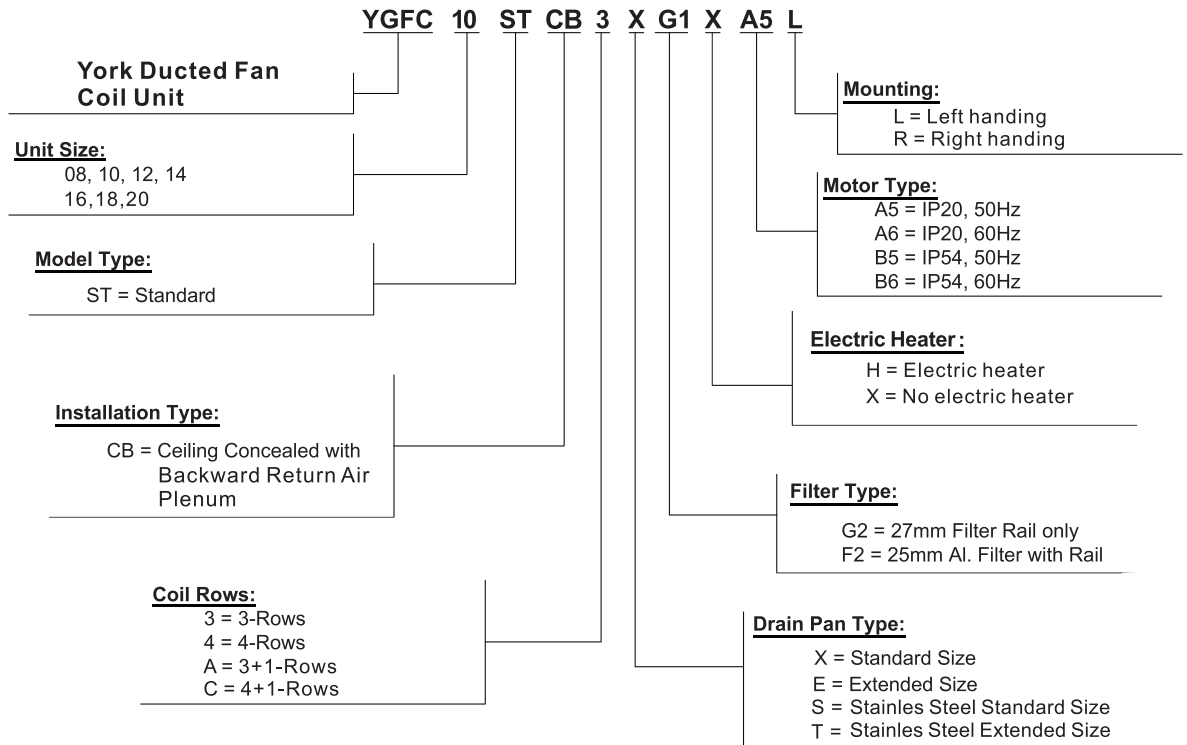

Outlines, Dimensions and Weight

Ceiling Concealed Model with Back Return Plenum

UNTI DIMENSIONS – ST TYPE

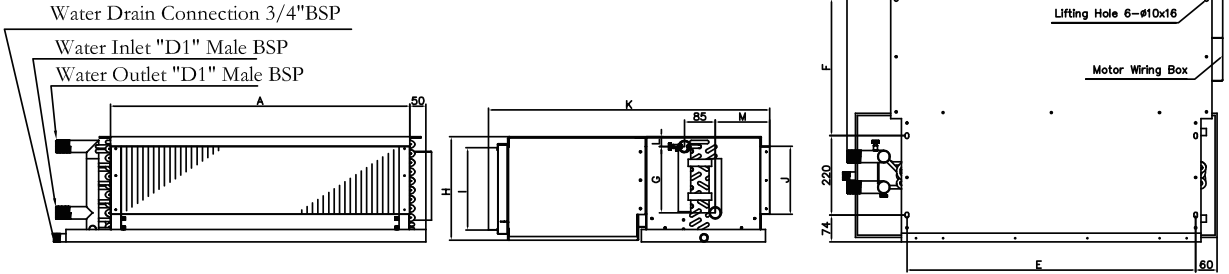

UNTI DIMENSIONS – DC TYPE

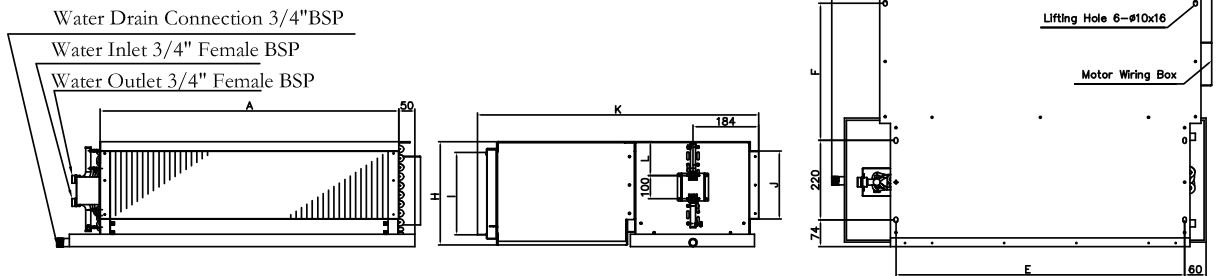

UNTI DIMENSIONS – ST A&B TYPE

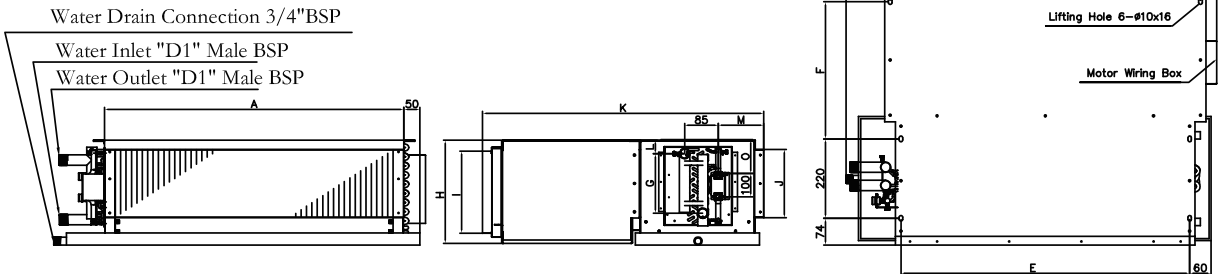

YDFC-MDE Installation, Operation and Maintenance Manual

SIZE	Type	A	B	B1	C	D	E	F	G	H	I	J	K	L	D1	M3R	M4R	N3+1	N4+1	O
08	ST	830	1050	1210	860	768	800	380	184	289	225	190	775	27	25	162	151	101	90	84
10		990	1210	1340	1020	928	960	380	184	289	225	190	775	27	25	162	151	101	90	84
12		990	1210	1340	1020	928	960	380	235	340	275	240	775	27	25	162	151	101	90	109
14		1120	1340	1480	1150	1058	1090	380	235	340	275	240	775	27	25	162	151	101	90	109
16		1120	1340	1480	1150	1058	1090	420	279	390	325	280	815	33	38.1	162	151	101	90	134
18		1260	1480	1610	1290	1198	1230	420	279	390	325	280	815	33	38.1	162	151	101	90	134
20		1390	1450	1710	1420	1328	1360	420	279	390	325	280	815	33	38.1	162	151	101	90	134
08	DC	830	1050	1210	860	768	800	380	-	289	225	190	775	83	19.05	-	-	-	-	-
10		990	1210	1340	1020	928	960	380	-	289	225	190	775	83	19.05	-	-	-	-	-
12		990	1210	1340	1020	928	960	380	-	340	275	240	775	108	19.05	-	-	-	-	-
14		1120	1340	1480	1150	1058	1090	380	-	340	275	240	775	108	19.05	-	-	-	-	-
16		1120	1340	1480	1150	1058	1090	420	-	390	325	280	815	134	19.05	-	-	-	-	-
18		1260	1480	1610	1290	1198	1230	420	-	390	325	280	815	134	19.05	-	-	-	-	-
20		1390	1450	1710	1420	1328	1360	420	-	390	325	280	815	134	19.05	-	-	-	-	-

Note:

(1)B is the length of drain pan. (2) B1 is the length of unit including extended drain pan. (3)All dimensions are in mm.

YDFC-MDE Installation, Operation and Maintenance Manual

Weight

Model	Net Weight(kg)	model	Net Weight(kg)
	CB		CB
YDFC 08 (3 Rows)	36.0	YDFC 08 E (3 Rows)	37.6
YDFC 10 (3 Rows)	38.0	YDFC 10 E (3 Rows)	39.3
YDFC 12 (3 Rows)	45.0	YDFC 12 E (3 Rows)	46.3
YDFC 14 (3 Rows)	50.0	YDFC 14 E (3 Rows)	51.4
YDFC 16 (3 Rows)	61.0	YDFC 16 E (3 Rows)	62.4
YDFC 18 (3 Rows)	74.0	YDFC 18 E (3 Rows)	75.3
YDFC 20 (3 Rows)	78.0	YDFC 20 E (3 Rows)	79.0
YDFC 08 (4 Rows)	40.0	YDFC 08 E (4 Rows)	41.6
YDFC 10 (4 Rows)	42.0	YDFC 10 E (4 Rows)	43.3
YDFC 12 (4 Rows)	49.0	YDFC 12 E (4 Rows)	50.3
YDFC 14 (4 Rows)	55.0	YDFC 14 E (4 Rows)	56.4
YDFC 16 (4 Rows)	66.0	YDFC 16 E (4 Rows)	67.4
YDFC 18 (4 Rows)	80.0	YDFC 18 E (4 Rows)	81.3
YDFC 20 (4 Rows)	84.0	YDFC 20 E (4 Rows)	85.0
YDFC 08 (A Rows)	41.6	YDFC 08 E (A Rows)	41.6
YDFC 10 (A Rows)	43.3	YDFC 10 E (A Rows)	43.3
YDFC 12 (A Rows)	50.3	YDFC 12 E (A Rows)	50.3
YDFC 14 (A Rows)	56.4	YDFC 14 E (A Rows)	56.4
YDFC 16 (A Rows)	67.4	YDFC 16 E (A Rows)	67.4
YDFC 18 (A Rows)	81.3	YDFC 18 E (A Rows)	81.3
YDFC 20 (A Rows)	85.0	YDFC 20 E (A Rows)	85.0
YDFC 08 (C Rows)	44.0	YDFC 08 E (C Rows)	45.6
YDFC 10 (C Rows)	46.0	YDFC 10 E (C Rows)	47.6
YDFC 12 (C Rows)	53.0	YDFC 12 E (C Rows)	54.3
YDFC 14 (C Rows)	60.0	YDFC 14 E (C Rows)	61.4
YDFC 16 (C Rows)	71.0	YDFC 16 E (C Rows)	72.4
YDFC 18 (C Rows)	86.0	YDFC 18 E (C Rows)	87.3
YDFC 20 (C Rows)	90.0	YDFC 20 E (C Rows)	91.0
Note:*E refers to extended drain pan			
*Standard(ST) model and District Cooling (DC) model have the same weight			

Fan Coil Start-Up Checklist

Install Checklist

<input type="checkbox"/> Equipment received as ordered.
<input type="checkbox"/> Unit checked for damage interior and exterior
<input type="checkbox"/> Make sure all ductwork is complete and available for full air flow
<input type="checkbox"/> Unit installed level to ensure proper drainage and operation
<input type="checkbox"/> Unit installed with proper clearances
<input type="checkbox"/> Ensure condensate water will drain toward the drain connection. An overflow drain may be required as a backup to a clogged primary drain
<input type="checkbox"/> Check that coil(s), valves and piping have been leak checked and insulated as required
<input type="checkbox"/> Main coil drain pan must be properly trapped and charged with water before units are started
<input type="checkbox"/> Ensure that all air has been vented from the system
<input type="checkbox"/> Return valves to their proper operating positions prior to start-up
<input type="checkbox"/> Repair any solder joint leaks and gently tighten any leaking valve packing nuts and piping accessories as required
<input type="checkbox"/> Install all panels
Note: If the motor and fan have been operated in the last (4) four weeks or more, lubricate all the bearings and rotate the motor and fan monthly to prevent moisture from accumulating in the bearings.

Cleaning Checklist

<input type="checkbox"/> Installer has cleaned out interior
<input type="checkbox"/> Ensure drain pan free from foreign material
<input type="checkbox"/> Ensure air filter are clean, installed properly and secured. Use the directional arrows or other information on the filter to determine the proper flow direction

Controls Checklist

<input type="checkbox"/> Check that supply voltage matches nameplate data
<input type="checkbox"/> Ensure that the unit is properly grounded
<input type="checkbox"/> Controls installation complete
<input type="checkbox"/> Check all electrical connections for tightness
<input type="checkbox"/> Review electrical print for correct wiring

Fan Inspection

<input type="checkbox"/> Check tightness of fan bearing lock collar
<input type="checkbox"/> With power off, check blower wheel set screws for tightness and ensure that the blower wheel(s) rotate freely and quietly
<input type="checkbox"/> Check tightness of all motor base and mounting bolts
<input type="checkbox"/> Check motor connections to ensure that they are secure and made in accordance with the wiring diagram
<input type="checkbox"/> Rotate all moving components manually. Adjust as required.
<i>The fan should be inspected and cleaned, in conjunction with maintenance of the motor and bearings. It is important to keep the wheel clean in order to avoid imbalance and vibration.</i>

Maintenance and Service of Product

Motor

The blower motor should be cleaned annually and if it has oiling ports, it should be oiled with a good grade of SAE 20 oil. Normally a few drops of oil in each bearing is sufficient.

If motor service is required, it can be removed in the following manner:

1. Disconnect electrical power to the unit at the disconnect switch and lock out.
2. Remove two screws, securing blower deck to unit.
3. Locate motor lead wires where they connect to the side panel, (lower rear on the electrical box side).
4. The quick connect plug needs to be squeezed on top and bottom to release it from its socket (dual motor units have two plugs).
5. Now slide blower / motor deck out of unit to service.
6. Reverse process to install.

Coil

The coil must be kept clean by any of the following methods.

1. Cleaning with low-pressure compressed air.
2. Flushing or rinsing with water (a detergent is advisable for greasy surfaces).
3. Prior to the water system start-up and balancing, the chilled/hot water systems should be flushed to clean out dirt and debris, which may have accumulated during construction. All unit service valves are to be closed during this process. Strainers are to be installed in the piping mains to prevent this material from entering the units during normal operation.

Filters



Clean or Replace Air Filters Regularly

The intervals at which filters require replacement depend on local conditions.

Because of dust and lint in the room, room-air filters load up much more rapidly than outdoor-air filters. Under normal conditions, the room air filter requires cleaning every six to eight weeks.

The filter is a permanent type and may be removed and washed with a garden hose. Filter should be completely dry before reinstalling. To remove the filter, rotate the retaining rod holding the front edge of the filter so it can drop below the front panel of the cabinet, then pull outward to remove. To reinstall the filter, slide the filter into the filter channels on both sides of the unit. Rotate filter retaining rod on lower front edge of cabinet door so that it is under the filter, then push the rod upward into the cabinet door.

To ensure proper maintenance of the filters, it is best to follow an organized maintenance procedure. The following one is recommended:

Divide the total number of units on the job into six equal groups. Each week inspect, clean or replace the filters in each group, in rotation. This insures a uniform servicing interval. The interval may be lengthened or shortened as determined by experience. If inspection shows only the room-air filter to be dirty, this one alone should be replaced.



Dirty filters reduce the air and heating capacities of the Unit. When the filters are excessively dirty, the unit heating capacity will be so reduced that it is ineffective for heating the room. When a room fails to heat, always check the filters.

Clean Unit Interior

Once a year clean the fans and coils of the unit thoroughly. Remove the access panel as necessary.

Wipe the interior of the unit clean with a rag. Wipe the motor and inside and outside of the fan housings. (In cooling units, clean out the drain pan)

Troubleshooting

Description / Possible Reasons	Suggestion
<p>Over-high Noise</p> <ul style="list-style-type: none"> ➤ Motor Shaft Destroyed ➤ Clamping screws of fan are loosened ➤ Volute distorts and impeller knocks 	<ul style="list-style-type: none"> ➤ Replace motor ➤ Tighten Screws ➤ Replace Fan
<p>Condensate Water Doesn't Discharge freely</p> <ul style="list-style-type: none"> ➤ Pipes Block ➤ Inclination degree is not enough 	<ul style="list-style-type: none"> ➤ Check pipe valves to find whether they are open or there is any foreign matter in it or not ➤ Regulate the height of the unit to set angle of inclination
<p>Motor is Burnt Out</p> <ul style="list-style-type: none"> ➤ Incorrect Wiring 	<ul style="list-style-type: none"> ➤ Replace motor and wiring according to wiring diagram strictly
<p>Air Volume is not enough</p> <ul style="list-style-type: none"> ➤ Resistance of duct exceeds the setting value ➤ Incorrect unit type ➤ Low Voltage 	<ul style="list-style-type: none"> ➤ Reduce resistance of duct or re-select unit ➤ Re-select unit ➤ Regulate voltage or re-select unit



YORK Guangzhou Air Conditioning & Refrigeration Co., Ltd.

Phone: +86 763 4681111

Fax: +86 763 4681114



© 2018 Johnson Controls, Inc.

www.johnsoncontrols.com

FORM NO.: YDFC MDE-03IOM(YGF)(1118)

SUPERSEDES: YDFC MDE-02IOM(YGF)(1111)



Printed on recycled paper

* Johnson Controls reserve all rights to product design changes without notification.

** Product performance detailed is agreed in the contract, this manual is for reference only.

SAP NO.: 660923